



ITT

Bell & Gossett

Installation, Operation, and Maintenance Manual

Series 80



Engineered for life

Table of Contents

Introduction and Safety	3
Introduction.....	3
Requesting other information.....	3
Safety.....	3
Safety terminology and symbols.....	4
Safety instruction decals.....	4
User safety.....	5
Environmental safety.....	6
Product warranty.....	7
Transportation and Storage	8
Inspect the delivery.....	8
Inspect the package.....	8
Inspect the unit.....	8
Pump lifting.....	8
Long-term storage.....	9
Product Description	10
General description.....	10
Operational specifications.....	10
Installation	12
Preinstallation.....	12
Pump location guidelines.....	12
Piping checklist.....	13
Typical installation.....	14
Commissioning, Startup, Operation, and Shutdown	15
Preparation for startup.....	15
Check the rotation.....	15
Prime the pump.....	16
Start the pump.....	16
Pump operation precautions.....	17
Shut down the pump.....	17
Note on the packed pump operation.....	17
Maintenance	19
Lubrication.....	19
Disassembly.....	19
Disassembly precautions.....	19
Drain the pump.....	19
Remove the pump assembly.....	19
Remove the impeller.....	20
Remove the mechanical seal (80 and 80-F)	20
Remove the seal or packing rings (80-S, 80-D, and 80-PF)	20
Remove the 2-inch single mechanical seal (80-S).....	20
Pre-assembly inspections.....	20
Replacement guidelines.....	20
Shaft and sleeve inspection.....	21
Reassembly.....	21
Assemble the standard mechanical seal (80 and 80-F)	21
Assemble the single mechanical seal (80-S)	22

Table of Contents

Assemble the 2-inch single mechanical seal (80-S).....	22
Assemble the double mechanical seal (80-D)	23
Assemble the packed stuffing box (80-PF)	25
Install the impeller.....	25
Reinstall the pump assembly.....	26
Screw torque values.....	26
Dealer servicing	26

Introduction and Safety

Introduction

Purpose of this manual

The purpose of this manual is to provide necessary information for:

- Installation
- Operation
- Maintenance



CAUTION:

Read this manual carefully before installing and using the product. Improper use of the product can cause personal injury and damage to property, and may void the warranty.

NOTICE:

Save this manual for future reference, and keep it readily available at the location of the unit.

Requesting other information

Special versions can be supplied with supplementary instruction leaflets. See the sales contract for any modifications or special version characteristics. For instructions, situations, or events that are not considered in this manual or in the sales documents, please contact the nearest ITT representative.

Always specify the exact product type and identification code when requesting technical information or spare parts.

Safety



WARNING:

- The operator must be aware of safety precautions to prevent physical injury.
 - Any pressure-containing device can explode, rupture, or discharge its contents if it is over-pressurized. Take all necessary measures to avoid over-pressurization.
 - Operating, installing, or maintaining the unit in any way that is not covered in this manual could cause death, serious personal injury, or damage to the equipment. This includes any modification to the equipment or use of parts not provided by ITT. If there is a question regarding the intended use of the equipment, please contact an ITT representative before proceeding.
 - This manual clearly identifies accepted methods for disassembling units. These methods must be adhered to. Trapped liquid can rapidly expand and result in a violent explosion and injury. Never apply heat to impellers, propellers, or their retaining devices to aid in their removal.
 - Do not change the service application without the approval of an authorized ITT representative.
-

**CAUTION:**

You must observe the instructions contained in this manual. Failure to do so could result in physical injury, damage, or delays.



Safety terminology and symbols

About safety messages

It is extremely important that you read, understand, and follow the safety messages and regulations carefully before handling the product. They are published to help prevent these hazards:

- Personal accidents and health problems
- Damage to the product
- Product malfunction

Hazard levels

Hazard level	Indication
 <p>DANGER:</p>	A hazardous situation which, if not avoided, will result in death or serious injury
 <p>WARNING:</p>	A hazardous situation which, if not avoided, could result in death or serious injury
 <p>CAUTION:</p>	A hazardous situation which, if not avoided, could result in minor or moderate injury
<p>NOTICE:</p>	<ul style="list-style-type: none"> • A potential situation which, if not avoided, could result in undesirable conditions • A practice not related to personal injury

Hazard categories

Hazard categories can either fall under hazard levels or let specific symbols replace the ordinary hazard level symbols.

Electrical hazards are indicated by the following specific symbol:



Electrical Hazard:

These are examples of other categories that can occur. They fall under the ordinary hazard levels and may use complementing symbols:

- Crush hazard
- Cutting hazard
- Arc flash hazard

Safety instruction decals



WARNING:

The maximum working pressure of the pump is listed on the nameplate. Do not exceed this pressure. Failure to follow these instructions can result in serious personal injury, death, and/or property damage.

Alert symbol

	<p>This safety alert symbol is used in manuals and on the safety instruction decals on the pump to draw attention to safety-related instructions.</p> <p>When used, the safety alert symbol means that failure to follow the instructions may result in a safety hazard.</p>
---	--

Decals

Make sure your pump has these safety instruction decals and that they are located as this figure shows. If the decals are missing or illegible, contact your local ITT representative for a replacement.

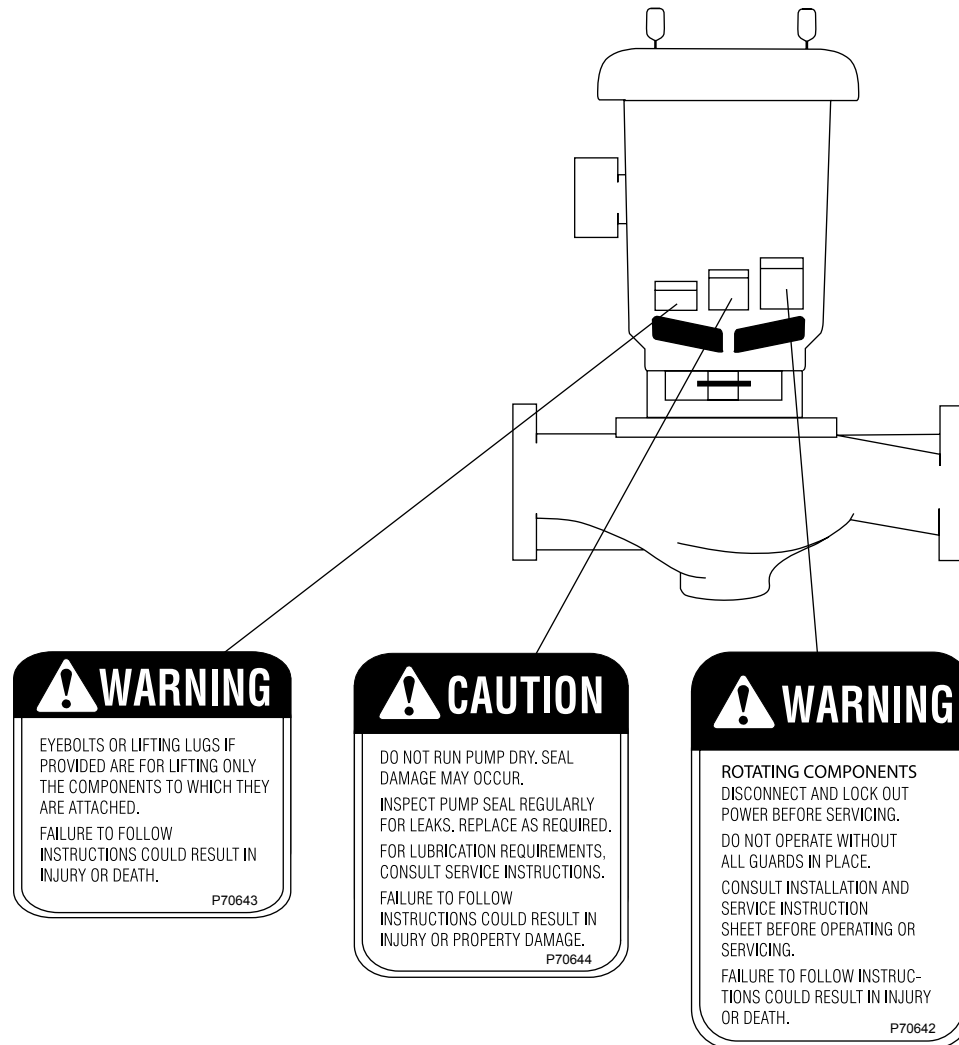

Make sure that all safety instruction decals are always clearly visible and readable.

User safety**General safety rules**

These safety rules apply:

- Always keep the work area clean.
- Pay attention to the risks presented by gas and vapors in the work area.
- Avoid all electrical dangers. Pay attention to the risks of electric shock or arc flash hazards.
- Always bear in mind the risk of drowning, electrical accidents, and burn injuries.

Safety equipment

Use safety equipment according to the company regulations. Use this safety equipment within the work area:

- Helmet
 - Safety goggles, preferably with side shields
 - Protective shoes
 - Protective gloves
 - Gas mask
 - Hearing protection
 - First-aid kit
 - Safety devices
-

NOTICE:

Never operate a unit unless safety devices are installed. Also see specific information about safety devices in other chapters of this manual.

Electrical connections

Electrical connections must be made by certified electricians in compliance with all international, national, state, and local regulations. For more information about requirements, see sections dealing specifically with electrical connections.

Precautions before work

Observe these safety precautions before you work with the product or are in connection with the product:

- Provide a suitable barrier around the work area, for example, a guard rail.
- Make sure that all safety guards are in place and secure.
- Make sure that you have a clear path of retreat.
- Make sure that the product cannot roll or fall over and injure people or damage property.
- Make sure that the lifting equipment is in good condition.
- Use a lifting harness, a safety line, and a breathing device as required.
- Allow all system and pump components to cool before you handle them.
- Make sure that the product has been thoroughly cleaned.
- Disconnect and lock out power before you service the pump.
- Check the explosion risk before you weld or use electric hand tools.

Wash the skin and eyes

Follow these procedures for chemicals or hazardous fluids that have come into contact with your eyes or your skin:

Condition	Action
Chemicals or hazardous fluids in eyes	<ol style="list-style-type: none">1. Hold your eyelids apart forcibly with your fingers.2. Rinse the eyes with eyewash or running water for at least 15 minutes.3. Seek medical attention.
Chemicals or hazardous fluids on skin	<ol style="list-style-type: none">1. Remove contaminated clothing.2. Wash the skin with soap and water for at least 1 minute.3. Seek medical attention, if necessary.

Environmental safety

The work area

Always keep the station clean to avoid and/or discover emissions.

Waste and emissions regulations

Observe these safety regulations regarding waste and emissions:

- Appropriately dispose of all waste.
- Handle and dispose of the processed liquid in compliance with applicable environmental regulations.
- Clean up all spills in accordance with safety and environmental procedures.
- Report all environmental emissions to the appropriate authorities.

Electrical installation

For electrical installation recycling requirements, consult your local electric utility.

Recycling guidelines

Always follow local laws and regulations regarding recycling.

Product warranty

Coverage

ITT undertakes to remedy faults in products from ITT under these conditions:

- The faults are due to defects in design, materials, or workmanship.
- The faults are reported to an ITT representative within the warranty period.
- The product is used only under the conditions described in this manual.
- The monitoring equipment incorporated in the product is correctly connected and in use.
- All service and repair work is done by ITT-authorized personnel.
- Genuine ITT parts are used.
- Only Ex-approved spare parts and accessories authorized by ITT are used in Ex-approved products.

Limitations

The warranty does not cover faults caused by these situations:

- Deficient maintenance
- Improper installation
- Modifications or changes to the product and installation made without consulting ITT
- Incorrectly executed repair work
- Normal wear and tear

ITT assumes no liability for these situations:

- Bodily injuries
- Material damages
- Economic losses

Warranty claim

ITT products are high-quality products with expected reliable operation and long life. However, should the need arise for a warranty claim, then contact your ITT representative.

Transportation and Storage

Inspect the delivery

Inspect the package

1. Inspect the package for damaged or missing items upon delivery.
2. Note any damaged or missing items on the receipt and freight bill.
3. File a claim with the shipping company if anything is out of order.
If the product has been picked up at a distributor, make a claim directly to the distributor.

Inspect the unit

1. Remove packing materials from the product.
Dispose of all packing materials in accordance with local regulations.
2. Inspect the product to determine if any parts have been damaged or are missing.
3. If applicable, unfasten the product by removing any screws, bolts, or straps.
For your personal safety, be careful when you handle nails and straps.
4. Contact your sales representative if anything is out of order.

Pump lifting



WARNING:

- Assembled units and their components are heavy. Failure to properly lift and support this equipment can result in serious physical injury and/or equipment damage. Lift equipment only at the specifically identified lifting points. Lifting devices such as eyebolts, slings, and spreaders must be rated, selected, and used for the entire load being lifted.
 - Crush hazard. The unit and the components can be heavy. Use proper lifting methods and wear steel-toed shoes at all times.
-

In order to lift the entire pump, use slings placed around the unit as shown.

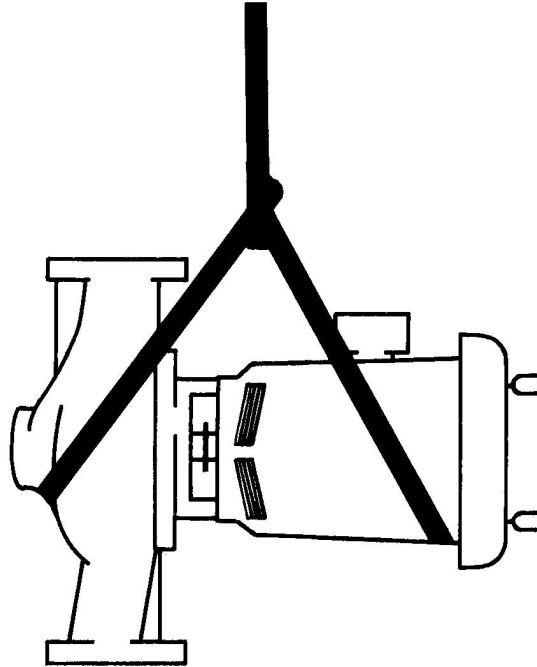

Figure 1: Proper lifting method

Long-term storage

If the unit is stored for more than 6 months, these requirements apply:

- Store in a covered and dry location.
- Store the unit free from heat, dirt, and vibrations.
- Rotate the shaft by hand several times at least every three months.

Treat bearing and machined surfaces so that they are well preserved. Refer to the drive unit and coupling manufacturers for their long-term storage procedures.

For questions about possible long-term storage treatment services, please contact your local ITT sales representative.

Product Description

General description

The pump is a centrifugal, close-coupled pump. These features make the pump easy to install, operate, and service:

- High efficiency
- Rugged bronze-fitted construction
- Horizontal or vertical in-line mounting

Intended applications



WARNING:

California Proposition 65 warning! This product contains chemicals known to the state of California to cause cancer and birth defects or other reproductive harm.

NOTICE:

This product is not intended for potable water applications.

The pump is intended for use with these pumped fluids:

- Unheated domestic and fresh water
- Boiler feed water
- Condensate
- Hydronic cooling or heating
- Benign liquids
- Pressure boosting
- General liquid transfer

Rotation

Pump rotation is clockwise when viewed from the back of the motor. An arrow is also located on the pump to show the direction of rotation.

Operational specifications

Mechanical seal specifications

This table describes the specifications of each mechanical seal type.

Seal type	Parameter	Value
Standard seals, BUNA ⁵	pH range limits for BUNA	pH 7–9
	Liquid temperature range that complies with the pH range limits for BUNA	-20°F to 225°F (-29°C to 107°C)
Standard seals, EPT ⁵ Optional seals, EPR carbon/ tungsten carbide	pH range limits for EPT	pH 7–11
	Liquid temperature range that complies with the pH range limits for EPT	-20°F to 250°F (-29°C to 121°C)
Flushed single seals ^{1,3,4}	pH range limits	pH 7–9
	Liquid temperature range	0°F to 250°F (-18°C to 121°C)
Flushed double seals ^{1,3,4}	pH range limits	pH 7–9
	Liquid temperature range	0°F to 250°F (-18°C to 121°C)

Seal type	Parameter	Value
Packing ²	pH range	pH 7–9
	Liquid temperature range	0°F to 200°F (-18°C to 93°C)

Table notes

1. An external flush is required on low pressure systems that contain a high concentration of abrasives.
2. Use packing on open or closed systems which require a large amount of makeup water, as well as systems that are subjected to a wide variety of chemical conditions and solids buildup.
3. For operating temperatures above 250°F, a cooled flush is required and is recommended for temperatures above 225°F for optimum seal life. On closed systems, cooling is accomplished by inserting a small heat exchanger in the flush line to cool the seal flushing fluid.
4. Flush-line filters and sediment separators are available on request.
5. Use a standard seal on closed or open systems that are relatively free of dirt and/or other abrasive particles.

Installation

Preinstallation

Precautions



WARNING:

- When installing in a potentially explosive environment, make sure that the motor is properly certified.
- You must earth (ground) all electrical equipment. This applies to the pump equipment, the driver, and any monitoring equipment. Test the earth (ground) lead to verify that it is connected correctly.
- Motors without built-in protection must be provided with contactors and thermal overload protection for single-phase motors, or starters with heaters for three-phase motors. (See the nameplate on the drive unit to select properly-sized overloads.)

NOTICE: Supervision by an authorized IIT representative is recommended to ensure proper installation. Failure to do so may result in equipment damage or decreased performance.

Evaluate the installation in order to determine that the Net Positive Suction Head Available (NPSH_A) meets or exceeds the Net Positive Suction Head Required (NPSH_R), as stated by the pump performance curve.

Pump location guidelines



WARNING:

Assembled units and their components are heavy. Failure to properly lift and support this equipment can result in serious physical injury and/or equipment damage. Lift equipment only at the specifically identified lifting points. Lifting devices such as eyebolts, slings, and spreaders must be rated, selected, and used for the entire load being lifted.

Guideline	Explanation/comment
Keep the pump as close to the liquid source as practically possible. If the pump is not on a closed system, locate the pump so that the fewest number of bends or elbows in the suction pipe are needed.	This minimizes the friction loss and keeps the suction piping as short as possible.
Make sure that the space around the pump is sufficient.	This facilitates ventilation, inspection, maintenance, and service.
If you require lifting equipment such as a hoist or tackle, make sure that there is enough space above the pump.	This makes it easier to properly use the lifting equipment and safely remove and relocate the components to a safe location.
Protect the unit from weather and water damage due to rain, flooding, and freezing temperatures.	This is applicable if nothing else is specified.
Do not install and operate the equipment in closed systems unless the system is constructed with properly-sized safety devices and control devices.	Acceptable devices: <ul style="list-style-type: none"> • Pressure relief valves • Compression tanks • Pressure controls • Temperature controls • Flow controls If the system does not include these devices, consult the engineer or architect in charge before you operate the pump.

Guideline	Explanation/comment
Take into consideration the occurrence of unwanted noise and vibration.	The best pump location for noise and vibration absorption is on a concrete floor with subsoil underneath.
If the pump location is overhead, undertake special precautions to reduce possible noise transmission.	Consider a consultation with a noise specialist.

Piping checklist



WARNING:

- The heating of water and other fluids causes volumetric expansion. The associated forces can cause the failure of system components and the release of high-temperature fluids. In order to prevent this, install properly sized and located compression tanks and pressure-relief valves. Failure to follow these instructions can result in serious personal injury or death, or property damage.
- Avoid serious personal injury and property damage. Make sure that the flange bolts are adequately torqued.
- Never force piping to make a connection with a pump.

Check	Explanation/comment	Checked
Check that a section of straight pipe, with a length that is five times its diameter, is installed between the suction side of the pump and the first elbow, or that a suction diffuser is installed.	This reduces suction turbulence by straightening the flow of liquid before it enters the pump.	
Check that the suction and discharge pipes are supported independently by use of pipe hangers near the pump .	This eliminates pipe strain on the pump .	
Check that there is a strong, rigid support for the suction and discharge lines.	As a rule, ordinary wire or band hangers are not adequate to maintain proper alignment.	
For pumps with flanges, check that the bolt holes in the pump flanges match the bolt holes in the pipe flanges.	—	
For pumps mounted in vertical piping with the motor in the horizontal position, check that adequate support is provided.	This prevents strain on the pump parts and piping. Do not mount the pump with the motor vertically downward. Do not use motor lift rings to suspend the pump.	
Check that the suction or discharge lines are not forced into position.	Coupling and bearing wear will result if suction or discharge lines are forced into position. The code for Pressure Piping (A.S.A.B. 31.1) lists many types of supports available for various applications.	
Check that fittings for absorbing expansion are installed in the system when considerable temperature changes are expected.	This helps to avoid strain on the pump.	
Check that you have a foot valve of equal or greater area than the pump suction piping when you use an open system with a suction lift.	Prevent clogging by using a strainer at the suction inlet next to the foot valve. Make sure that the strainer has an area three times that of the suction pipe with a mesh hole diameter of no less than 0.25 in. (0.64 cm).	
Check that flexible piping is used on both the suction and discharge sides of the pump when you use an isolation base.	—	

Check	Explanation/comment	Checked
Check that a triple duty valve is installed in the discharge line.	This valve serves as a check valve that protects the pump from water hammer, and serves as an isolation valve for servicing and for throttling.	
Check that the pipeline has isolation valves around the pump and has a drain valve in the suction pipe.	—	
Use Teflon tape sealer or a high quality thread sealant when you install the suction and discharge connections to a threaded pump housing.	—	

Typical installation

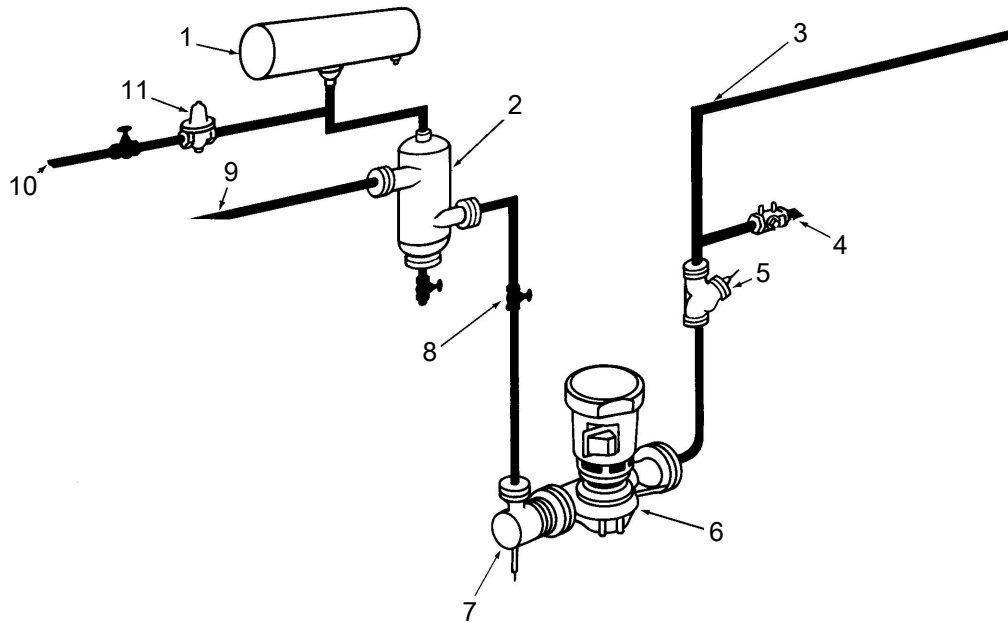

1. Compression tank (located in the suction piping)
2. Air separator
3. System supply
4. Circuit setter
5. Triple duty valve
6. Pump
7. Suction diffuser
8. Isolation valve
9. Pipe from boiler, chiller, or converter
10. Cold water supply
11. Reducing valve

Commissioning, Startup, Operation, and Shutdown

Preparation for startup



WARNING:

- Failure to follow these precautions before you start the unit will lead to serious personal injury and equipment failure.
- Do not operate the pump below the minimum rated flows or with the suction or discharge valves closed. These conditions can create an explosive hazard due to vaporization of pumped fluid and can quickly lead to pump failure and physical injury.
- If the pump, motor, or piping operate at extremely high or low temperatures, then guarding or insulation is required. Failure to follow these instructions can result in serious personal injury or death, and property damage.
- Always disconnect and lock out power to the driver before you perform any installation or maintenance tasks. Failure to disconnect and lock out driver power will result in serious physical injury.
- Operating the pump in reverse rotation can result in the contact of metal parts, heat generation, and breach of containment.

Precautions

NOTICE:

- Verify the driver settings before you start any pump.
- Make sure that the warm-up rate does not exceed 2.5°F (1.4°C) per minute.

You must follow these precautions before you start the pump:

- Flush and clean the system thoroughly to remove dirt or debris in the pipe system in order to prevent premature failure at initial startup.
- Bring variable-speed drivers to the rated speed as quickly as possible.
- Run a new or rebuilt pump at a speed that provides enough flow to flush and cool the close-running surfaces of the stuffing-box bushing.
- If temperatures of the pumped fluid will exceed 200°F (93°C), then warm up the pump prior to operation. Circulate a small amount of fluid through the pump until the casing temperature is within 100°F (38°C) of the fluid temperature.

At initial startup, do not adjust the variable-speed drivers or check for speed governor or over-speed trip settings while the variable-speed driver is coupled to the pump. If the settings have not been verified, then uncouple the unit and refer to instructions supplied by the driver manufacturer.

Check the rotation



WARNING:

- Operating the pump in reverse rotation can result in the contact of metal parts, heat generation, and breach of containment.
- Always disconnect and lock out power to the driver before you perform any installation or maintenance tasks. Failure to disconnect and lock out driver power will result in serious physical injury.

1. Unlock power to the driver.
2. Make sure that everyone is clear, and then jog the driver long enough to determine that the direction of rotation corresponds to the arrow on the pump.

3. Lock out power to the driver.

Prime the pump



CAUTION:

Do not run the pump dry.

Make sure that the pump body is full of liquid before startup. If the system does not automatically fill the pump body with liquid, then you must manually prime the pump.

1. Loosen the vent plugs on the pump body.
2. While venting the air from the pump body, rotate the pump shaft a few times by hand.
3. After all air has been purged from the pump, close the vent plugs.

Start the pump



CAUTION:

- Observe the pump for vibration levels, bearing temperature, and excessive noise. If normal levels are exceeded, shut down the pump and resolve the issue.
-

Before you start the pump, you must perform these tasks:

- Open the suction valve.
 - Open any recirculation or cooling lines.
1. Fully close or partially open the discharge valve, depending on system conditions.
 2. Start the driver.
 3. Slowly open the discharge valve until the pump reaches the desired flow.
 4. Immediately check the pressure gauge to ensure that the pump quickly reaches the correct discharge pressure.
 5. If the pump fails to reach the correct pressure, perform these steps:
 - a) Stop the driver.
 - b) Prime the pump again.
 - c) Restart the driver.
 6. Monitor the pump while it is operating:
 - a) Check the pump for bearing temperature, excessive vibration, and noise.
 - b) If the pump exceeds normal levels, then shut down the pump immediately and correct the problem.
 7. Repeat steps 5 and 6 until the pump runs properly.

Pump operation precautions

General considerations



CAUTION:

- Vary the capacity with the regulating valve in the discharge line. Never throttle the flow from the suction side since this can result in decreased performance, unexpected heat generation, and equipment damage.
- Do not overload the driver. Driver overload can result in unexpected heat generation and equipment damage. The driver can overload in these circumstances:
 - The specific gravity of the pumped fluid is greater than expected.
 - The pumped fluid exceeds the rated flow rate.
- Make sure to operate the pump at or near the rated conditions. Failure to do so can result in pump damage from cavitation or recirculation.

Operation at reduced capacity



WARNING:

Never operate any pumping system with a blocked suction and discharge. Operation, even for a brief period under these conditions, can cause confined pumped fluid to overheat, which results in a violent explosion. You must take all necessary measures to avoid this condition.



CAUTION:

- Avoid excessive vibration levels. Excessive vibration levels can damage the bearings, stuffing box or seal chamber, and the mechanical seal, which can result in decreased performance.
- Avoid increased radial load. Failure to do so can cause stress on the shaft and bearings.
- Avoid heat build-up. Failure to do so can cause rotating parts to score or seize.
- Avoid cavitation. Failure to do so can cause damage to the internal surfaces of the pump.

Operation under freezing conditions

NOTICE:

Do not expose an idle pump to freezing conditions. Drain all liquid that is inside the pump and the flush lines. Failure to do so can cause liquid to freeze and damage the pump.

Shut down the pump

1. Slowly close the discharge valve.
2. Shut down and lock the driver to prevent accidental rotation.

Note on the packed pump operation

Tighten the gland nuts

Before you start the pump, back off the packing gland nuts or screws until the gland is loose.

Hand tighten until the gland is snug against the first packing ring. Initially, water might freely run from the packing. This is normal and should be allowed to continue for a period of time before you continue to tighten the gland. Tighten the gland nuts slowly and one flat at a time.

Leakage rate

An adequate leakage rate is not one single value for all pumps and installations, but is the amount required to provide adequate cooling and lubrication. The required leakage is influenced by operating pressure, fluid temperature, shaft speed, and so forth. For fluid temperatures in the range of 32°F to 190°F (0°C to 88°C), average leakage rates of 60 to 80 drops per minute are recommended. However, each individual pump and installation has unique operating conditions that result in widely-variable leakage rate requirements.

Maximum fluid temperature

At fluid operating temperatures near the upper limit of 190°F (88°C), the maximum temperature rise of the leakage is important. Never operate a packed pump with steam forming at the gland. This limits the temperature rise to a maximum of about 20°F (-7°C). If the formation of steam persists at higher leakage rates, you must provide cooling water by means of an external supply, or a heat exchanger used to cool the bypass flush.

Maintenance

Lubrication

The pump motor has been lubricated at the factory. Keep the motor properly lubricated in accordance with the motor manufacturer's instructions.

Disassembly

Disassembly precautions

**WARNING:**

- This manual clearly identifies accepted methods for disassembling units. These methods must be adhered to. Trapped liquid can rapidly expand and result in a violent explosion and injury. Never apply heat to impellers, propellers, or their retaining devices to aid in their removal.
- Make sure that the pump is isolated from the system and that pressure is relieved before you disassemble the pump, remove plugs, open vent or drain valves, or disconnect the piping.
- Always disconnect and lock out power to the driver before you perform any installation or maintenance tasks. Failure to disconnect and lock out driver power will result in serious physical injury.
- Crush hazard. The unit and the components can be heavy. Use proper lifting methods and wear steel-toed shoes at all times.

NOTICE:

Make sure that all replacement parts are available before you disassemble the pump for overhaul.

Drain the pump

**CAUTION:**

- Allow all system and pump components to cool before you handle them to prevent physical injury.

1. Close the isolation valves on the suction and discharge sides of the pump.
You must drain the system if no valves are installed.
2. Open the drain valve.
Do not proceed until liquid stops coming out of the drain valve. If liquid continues to flow from the drain valve, the isolation valves are not sealing properly and you must repair them before you proceed.
3. Leave the drain valve open and remove the drain plug located on the bottom of the pump housing.
Do not reinstall the plug or close the drain valve until the reassembly is complete.
4. Drain the liquid from the piping and flush the pump if it is necessary.
5. Disconnect all auxiliary piping and tubing.

Remove the pump assembly

1. Loosen the volute capscrews but do not remove them.
2. Use the capscrews in the jackscrew holes in order to loosen the pump assembly from the volute.

**WARNING:**

Pressurized device. Make sure that the internal pressure is relieved before you continue.

3. Remove the seal flushing tube if it is used.

4. Remove the volute capscrews.
5. Remove the pump assembly from the volute.

Remove the impeller



WARNING:

Never apply heat to remove an impeller. The use of heat may cause an explosion due to trapped liquid, resulting in severe physical injury and property damage.



CAUTION:

Wear heavy work gloves when you handle impellers. The sharp edges can cause physical injury.

1. Remove the impeller capscrew.
2. Remove the lockwasher and the washer.
3. Remove the impeller.

Remove the mechanical seal (80 and 80-F)

1. Remove the rotating portion of the seal.
If necessary, use a screwdriver to loosen the rubber ring.
2. Remove the seal insert, the insert gasket, and the retainer if it is used.

Remove the seal or packing rings (80-S, 80-D, and 80-PF)

1. Remove the hex nuts from the seal cap bolts.
2. For the 80-PF, remove the hex nuts that hold the packing gland to the stuffing box.
3. Remove the coverplate screws.
4. Remove the coverplate from the bracket.
5. Remove the seal assembly or packing rings.

Remove the 2-inch single mechanical seal (80-S)

1. Remove the screws from the seal gland.
2. Remove the coverplate screws.
3. Remove the coverplate from the bracket.
4. Remove the seal assembly.

Pre-assembly inspections

Guidelines

Before you assemble the pump parts, make sure you follow these guidelines:

- Inspect the pump parts according to the information in these pre-assembly topics before you reassemble your pump. Replace any part that does not meet the required criteria.
- Make sure that the parts are clean. Clean the pump parts in solvent in order to remove oil, grease, and dirt.

NOTICE: Protect machined surfaces while you clean the parts. Failure to do so may result in equipment damage.

Replacement guidelines

Impeller replacement

This table shows the criteria for replacing the impeller:

Impeller parts	When to replace
Impeller vanes	<ul style="list-style-type: none"> • When grooved deeper than 1/16 in. (1.6 mm), or • When worn evenly more than 1/32 in. (0.8 mm)
Vane edges	When you see cracks, pitting, or corrosion damage

Gaskets, O-rings, and seats replacement

- Replace all gaskets and O-rings at each overhaul and disassembly.
- Inspect the seats. They must be smooth and free of physical defects.
- Replace parts if the seats are defective.

Shaft and sleeve inspection

Inspection criteria

Inspect the shaft and sleeve according to this criteria:

- Thoroughly clean the shaft and sleeve.
- Thoroughly clean the coverplate seal cavity.
- Inspect the surface for damage such as pitting, corrosion, nicks, and scratches.

Replace these parts if they are damaged.

Reassembly

Assemble the standard mechanical seal (80 and 80-F)

1. Lubricate the shaft sleeve and coverplate seal cavity with soapy water. Do not use a petroleum lubricant.
2. Install a new insert gasket.
3. Install a new seal insert and make sure that the indentation is against the insert gasket.
4. Slide a new rotating seal assembly onto the shaft sleeve.
5. Push the top of the compression ring with a screwdriver until the seal is tight against the seal insert.
6. Install the seal spring and point the narrow end toward the seal.

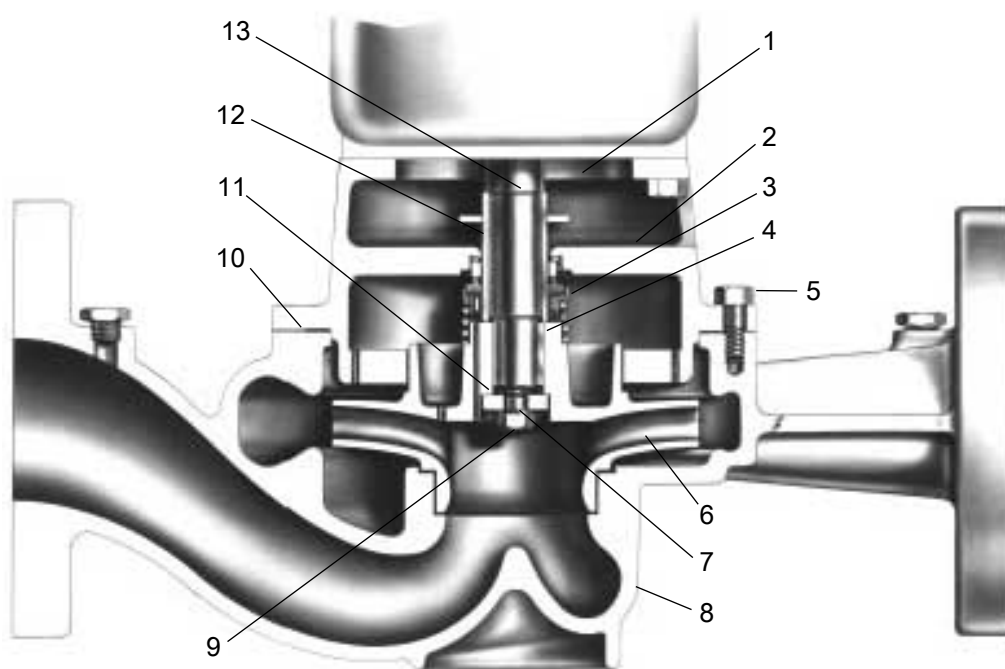

1. Slinger
2. Bracket coverplate

3. Seal assembly
4. Impeller key
5. Volute capscrew
6. Impeller
7. Impeller lockwasher
8. Volute
9. Impeller capscrew
10. Volute gasket
11. Impeller washer
12. Shaft sleeve
13. Shaft

Figure 2: Standard mechanical seal

Assemble the single mechanical seal (80-S)

1. Lubricate the shaft sleeve and seal cap with soapy water.
Do not use a petroleum lubricant.
2. Insert a stationary seal with an O-ring into the seal cap and slide it onto the shaft.
3. Replace the seal cap gasket.
4. Slide the rotating portion of the seal assembly onto the shaft sleeve and lock it in place.

ID seal size	Distance between collar and impeller end of the shaft sleeve
1-1/4 in. (3.175 cm)	1-13/32 in. (3.571 cm)
1-5/8 in. (4.128 cm)	1-1/4 in. (3.175 cm)

5. Assemble the coverplate onto the bracket.
6. Tighten the capscrews according to the Capscrew torque table.
7. Attach the seal cap to the coverplate.
8. Tighten the hex nuts on the seal cap bolts according to the Capscrew torque table.

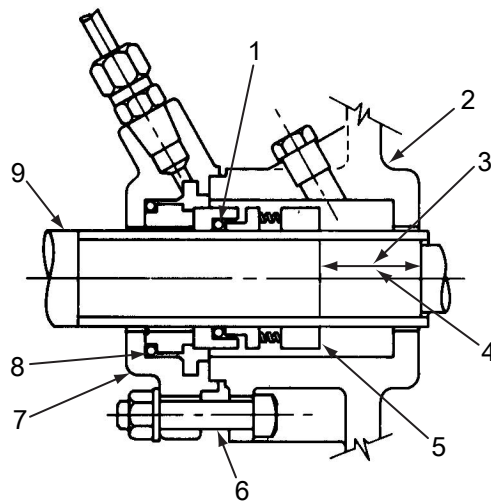

1. O-ring
2. Coverplate
3. For 1-1/4 in. seal: 1-13/32 in. (3.571 cm)
4. For 1-5/8 in. seal: 1-1/4 in. (3.175 cm)
5. Seal locking collar
6. Seal cap bolt
7. Seal cap
8. O-ring
9. Motor end

Figure 3: Single mechanical seal (1531-S)

Assemble the 2-inch single mechanical seal (80-S)

1. Lubricate the shaft sleeve with soapy water.

- Do not use a petroleum lubricant.
2. Slide the stationary seal with an O-ring onto the shaft.
 3. Slide the rotating portion of the seal assembly onto the shaft sleeve and lock it in place a distance of 55/64 in. (2.813 cm) from the seal collar to the impeller end of the shaft sleeve.
 4. Assemble the coverplate onto the bracket.
 5. Tighten the capscrews according to the Capscrew torque table.
 6. Attach the seal gland to the coverplate.
 7. Tighten the capscrews to the seal gland according to the Capscrew torque table.

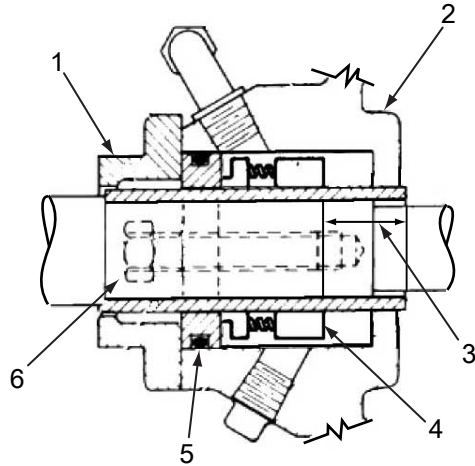

1. Seal gland
2. Coverplate
3. For 2 in. seal: 55/64 in. (2.813 cm)
4. Seal locking collar
5. O-ring
6. Seal gland cap screw

Figure 4: 2-inch single mechanical seal

Assemble the double mechanical seal (80-D)

1. Lubricate the shaft sleeve, seal cap, and coverplate cavity with soapy water.
Do not use a petroleum lubricant.
2. Insert a stationary seal and O-ring into the seal cap.
For the 1-1/4 in. ID seal, both parts are housed in the coverplate. A seal cap gasket is not used.

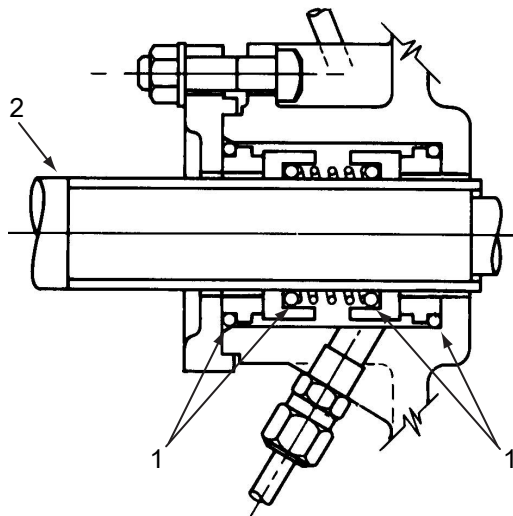

- 1. O-rings
- 2. Motor end

Figure 5: Double mechanical seal (1531-D)

- 3. Insert another stationary seal and O-ring into the coverplate.
- 4. Slide the seal cap onto the shaft.
- 5. Replace the seal cap gasket.
- 6. Slide the rotating portion of the seal assembly onto the shaft sleeve.
- 7. Assemble the coverplate onto the bracket.
- 8. Tighten the capscrews according to the Capscrew torque values table.
- 9. Attach the seal cap to the coverplate.
- 10. Tighten the hex nuts on the seal cap bolts according to the Capscrew torque values table.

Assemble the packed stuffing box (80-PF)

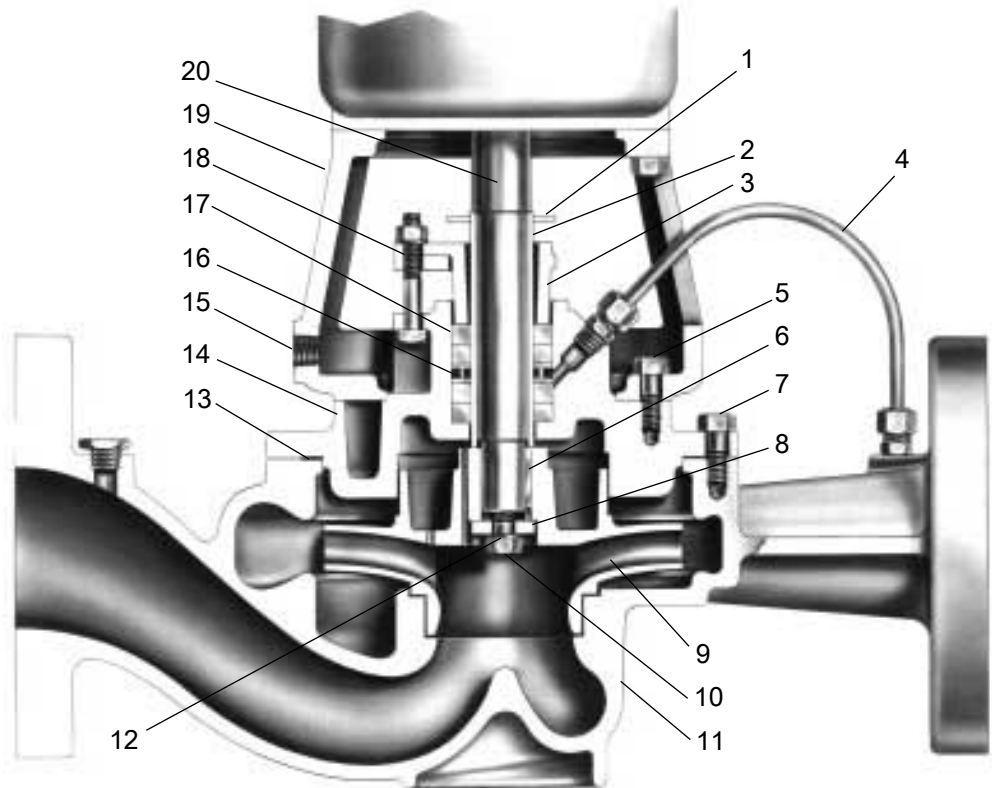

1. Slinger
2. Shaft sleeve
3. Packing gland
4. Flush line
5. Coverplate capscrew
6. Impeller key
7. Volute capscrew
8. Impeller washer
9. Impeller
10. Impeller capscrew
11. Volute
12. Impeller lockwasher
13. Volute gasket
14. Coverplate
15. Drip drain
16. Lantern ring
17. Packing
18. Gland bolt
19. Bracket
20. Shaft

Figure 6: Packed stuffing box

1. Insert two packing rings into the stuffing box.
2. Insert the lantern ring and the last two pieces of packing.
Make sure that the joints on the packing rings are staggered 90°.
3. Install, but do not tighten, the packing gland.
4. Install the coverplate over the pump shaft.
5. Tighten the capscrews according to the Capscrew torque table in the Maintenance chapter.
6. Tighten the packing gland to compress the packing.
See the note on the packed pump operation in the Operations chapter for more information.

Install the impeller





1. Install the impeller, impeller washer, lockwasher, and capscrew.
2. Tighten the capscrew according to the Capscrew torque values table.

Reinstall the pump assembly

1. Install a new volute gasket.
2. Install the pump assembly into the volute.
3. Tighten the volute capscrews according to the Capscrew torque table.
4. Install a seal flushing tube if it is used.
5. Install the drain plug and close the drain valve.
6. Open the isolation valves and inspect the pump for leaks.
7. Return the pump to service if it is not leaking.

Screw torque values

Capscrew torque in ft-lb (Nm)

Capscrew type	Head marking	Capscrew diameter (in inches)								
		1/4	5/16	3/8	7/16	1/2	5/8	3/4	7/8	1
SAE grade 2		6 (8)	13 (18)	25 (34)	38 (52)	60 (81)	120 (163)	190 (258)	210 (285)	300 (407)
Brass and stainless steel		4 (5)	10 (14)	17 (23)	27 (37)	42 (57)	83 (113)	130 (176)	200 (271)	300 (407)
	or 									
SAE grade 5		10 (14)	20 (27)	35 (47)	60 (81)	90 (122)	180 (244)	325 (440)	525 (712)	800 (1085)

Dealer servicing

If trouble occurs that cannot be rectified, contact your local ITT representative and be prepared to provide this information:

1. Complete nameplate data of pump and motor
2. Suction and discharge pipe pressure gauge readings
3. Ampere draw of the motor
4. A sketch of the pump hook-up and piping



ITT

Visit our Web site for the latest version of this document and more information
<http://www.bellgossett.com>

ITT - Bell & Gossett
8200 N. Austin Avenue
Morton Grove, IL 60053
USA
Tel. 1-847-966-3700
Fax 1-847-966-9052