



Bell & Gossett®
 Instruction Manual 6-71-075-110



The ecocirc® auto/vario Series Pumps
 Installation, Operation and Service Instructions

INSTALLER: PLEASE LEAVE THIS MANUAL FOR THE OWNER'S USE.

WARNING: Before Installing, using or servicing this product, read the instructions. To reduce risk of electrical shock see instructions for proper installation.

CAUTION: For supply connections use wire suitable for at least 105°C. Use copper conductors only. Employer des fils d'alimentation adequats pour 105°C. For indoor use only. Employer uniquement a l'interieur.

WARNING: Risk of electric shock; this pump has not been investigated for use in swimming pool and marine areas. - **Non submersible Pump** -

Description

B&G centrifugal pumps are designed for circulation and transfer of a variety of fluids compatible with their materials of construction limited to maximum fluid temperatures and maximum line pressures as indicated below. Unique leakproof integrated motor/pump design eliminates the need for conventional mechanical seals or other shaft sealing devices. They are self lubricating and require no external lubrication.

Model auto/vario Cast Iron may be used for water circulating in hydronic systems.
 Model auto/vario Bronze may be used for water circulation applications in domestic hot water systems.
 Model auto/vario circulators have not been investigated, nor is it intended for use in swimming pool and marine areas.

auto/vario Specifications

	Min Fluid Temp	Max Fluid Temp	Max Pressure	Max Ambient Temp	Voltage Range	Freq	Rated Wattage	Max RPM's
	(°C) (°F)	(°C) (°F)	(bar) (PSI)	(°C) (°F)	(V)	(Hz)	(W)	
Cast Iron flanged	5 40	95 203	10 150	40 104	115/230	50/60	60	3100
Bronze	5 40	95 203	10 150	40 104	115/230	50/60	60	3100

Materials of Construction (wetted parts)

Part	Materials
Pump Housing	Cast Iron or Bronze
"O" Ring	EPDM or Viton
Impeller	Nylon/PPO
Bearing	Carbon/Allumina Ceramic
All Other Wetted Parts	316 Stainless Steel or Plastic

Fig. 1

Unpacking

When unpacking the unit inspect carefully for any damage that may have occurred during transit. Check for loose, damaged, or missing parts. Do not attempt to assemble or operate pump if any parts are missing or damaged.

General Safety Information

1. Know the pump application, limitations and potential hazards.

WARNING: Pump should only be used with liquids compatible with pump component materials. Do not use to pump flammable or explosive fluids such as gasoline, fuel oil, kerosene, etc. Do not use in flammable and/or explosive atmospheres.

CAUTION: These pumps have been evaluated for use with water only. For your protection always wear proper clothing, eye protection, etc. in case of any malfunction. For proper handling techniques and precautions, contact your supplier, insurance company and local agencies (fire dept., etc.). Failure to comply with this warning may result in personal injury and/or property damage.

2. Ensure that the power source conforms to the requirements of your equipment.
3. Disconnect power before servicing. If the power disconnect is out of sight, lock in the open position and tag it to prevent unexpected application of power. Failure to do so may result in a fatal electric shock!
4. Release all pressure within the system before servicing any component.
5. Drain liquids from the system before servicing.
6. Personal Safety:
 - a. Wear safety glasses at all times when working with pumps.
 - b. Keep work area clean, uncluttered, and properly lighted. Replace all unused tools and equipment.
 - c. Keep visitors at a safe distance from the work area.
 - d. Make workshop childproof with padlocks, master switches and by removing starter keys.
7. The motor is designed to be used in a clean dry location with access to an adequate supply of cooling air.
8. When wiring an electrically driven pump follow all electrical and safety codes.
9. Single phase motors: All units are supplied with 115 volt, single phase motors.
10. All wiring should be performed by a qualified electrician.

WARNING: Do not handle a pump or pump motor with wet hands or when standing on a wet or damp surface or in water.

Australia

This pump must be installed in accordance with AS3500

Installation

The pump should not be used in flammable or explosive atmospheres. For installations where property damage might result from an inoperative or leaking pump, provide a drip pan to collect leakage. Failure to follow any warning can result in personal injury and/or property damage.

1. Support the piping independently of the pump. B&G pumps are lubricated by the pumped fluid. How they are mounted and the condition of the water in the system are important. THOROUGHLY CLEAN and FLUSH the system before installing the pump. If the fluid contains a high level of dissolved solids such as dirt, sediment, or products of corrosion, a strainer and/or filter should be installed at least 12" before the inlet to the pump.

Mounting

For installation purposes the arrows on the pump housing indicate the direction of water flow through the pump. Check to make sure the pump is adequately supported and that neither the pump or the piping is stressed. Install the pump at a point closest to the highest static pressure point, but above the absolute lowest point in the system to avoid dirt and sediment build-up. If required by application and code, install a safety relief valve to protect against over temperature and pressure. Do not mount with the motor above the impeller. This can cause the pump to run dry leading to premature failure of the pump which voids the warranty.

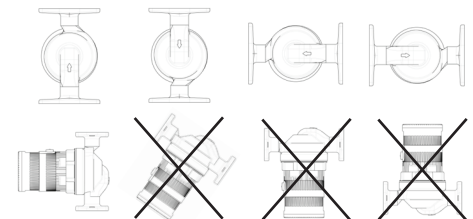

Fig. 2

Electrical

These instructions must be followed to reduce risk of electrical shock. All work should be performed by a qualified electrician and in accordance with the current national and local electrical codes and regulations. Consult the nameplate for electrical data. The motor is protected. Make certain that a properly sized circuit is available. Wire size should be based on the current carrying (amp) capacity of the conductor. The pump must be grounded in accordance with the current national and local codes. Ground wire should be copper with a current capacity at least equal to that of the wire carrying power to the pump. Observe all minimum code requirements for your jurisdiction. Isolation valves are recommended for both sides of the pump. Valves should be positioned to avoid leakage onto the motor and electrical compartment. All elbows, tees, and sharp bends in the piping should be installed sufficiently upstream or downstream of the suction and discharge ports. Avoid welding or soldering close to the pump,

which could cause damage to the unit. After installation, the end product must comply with the relevant product standard. Product standard regulations must be observed during fitting and electric installation. Installation and electric connections shall be carried out by professionals only.

Electrical Safety

⚠ WARNING: - Electrical Shock Hazard - Electrical connections are to be made by a qualified electrician in accordance with all applicable codes, ordinances and good practices. Failure to follow these instructions could result in serious personal injury, death and/or property damage.

⚠ WARNING: - Electrical Grounding Hazard - Adequate electrical grounding is required for the safe operation of B&G Pumps. Ground the pump back to the service using a copper conductor at least the size of the circuit connectors supplying the pump. Connect the ground wire to the ground terminal in the wiring compartment. Failure to follow these instructions could result in serious personal injury, death and/or property damage.

⚠ WARNING: - Risk of Electric Shock - If this pump is supplied with a grounding conductor and grounding-type attachment plug, to reduce the risk of electric shock, be certain that it is connected only to a properly grounded, grounding-type receptacle.

⚠ WARNING: - Risk of Electric Shock - Do not install this pump in swimming pool or marine areas. Failure to follow these instructions could result in serious personal injury, death and/or property damage.

Wiring Instructions

1. Loosen the screw securing the motor cover (wiring compartment), and remove the screw & cover.
2. Attach the appropriate size connector to one of the holes in the side of the conduit box.
3. Using a minimum size of 14 AWG copper electrical wire (refer to your local code for wiring instructions), wire the motor to a single phase power source that matches the electrical rating on the pump nameplate. See Fig.3. Use the size of electrical wire as dictated by local code.
4. Connect the ground wire to one of the ground screws inside the conduit box. See Fig. 3.
5. Make sure electrical connections are secured before replacing the motor cover.

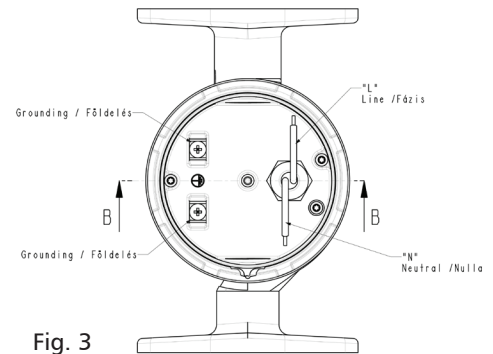

Fig. 3

Operation

1. Completely fill and pressurize the system before operating the pump. Do not start the pump until the system has been filled. Make sure the isolation valves are fully open and that there is water in the pump.
2. Purge air from the system prior to operating the pump. These two steps are very important. The pump should never be allowed to run dry. This can severely damage the pump and will void the warranty.
3. Operate the pump for approximately 10 minutes at full speed (speed 7 on the dial) to purge any remaining air in the system. It may be necessary to open a discharge valve, port and/or fixture to ensure that the air has been purged. The pump should be running quietly. If a "gurgling" noise is present it may mean there is still air in the system. Turning the pump on and off several times will generally clear the remaining air. If this "gurgling" noise persists, recheck the system and re-purge the air. System and pump should now operate quietly and efficiently.

⚠ WARNING: Ensure that the unit is disconnected from the power source before attempting to service or remove any components.

Maintenance

1. Since the rotor/impeller unit (see exploded views) is the only moving part, its replacement is simple.
2. After the power has been disconnected using a counter clockwise motion remove the screw ring housing to motor connection.
3. Remove the "O" ring from the pump housing.
4. Remove and replace the rotor.
5. Replace the "O" ring with a new one and reverse the disassembly procedure to reassemble the pump.
6. Since these units are self lubricated by the pumped fluid, they never need external lubrication.
7. Pump should be drained when subjected to freezing temperatures.
8. If provided, the suction line strainer should be cleaned at regular intervals.

Removal of Pump From Existing System For Replacement

⚠ WARNING: - Electrical Shock Hazard - Disconnect and lockout the power before servicing. Failure to follow these instructions could result in serious personal injury, death and/or property damage.

⚠ WARNING: - Excessive Pressure Hazard Volumetric Expansion - The heating of water and other fluids causes volumetric expansion. The associated forces may cause failure of system components and the release of high temperature fluids. This can be prevented by installing properly sized and located compression tanks and pressure relief valves. Failure to follow these instructions could result in serious personal injury, death and/or property damage.

Trouble Shooting Chart

LED Indicator:

Solid green LED indicates pump is powered and functioning properly. If flashing green LED please contact your local B&G representative for assistance.

Symptom	Possible Causes	Corrective Action
Motor will not start or run	1. Improperly wired 2. Blown fuse or open circuit breaker 3. Loose or broken wiring 4. Foreign object in impeller 5. Motor shorted out 6. Dry run cutout has opened circuit	1. Check motor wiring diagram 2. Replace fuse or circuit breaker after reason for overload has been corrected 3. Tighten connections, repair wiring 4. Disassemble pump, remove object 5. Replace motor 6. Allow unit to cool, restart after reason for cutout has been determined and corrected
Pump will not prime	1. Leak, obstruction, or kink in suction line 2. Suction line closed 3. Pump is worn	1. Repair as necessary 2. Open 3. Replace parts
Little or no discharge	1. Housing not filled with water 2. Suction piping too small 3. Total head too high 4. Impeller plugged 5. Pump not running	1. Properly prime housing 2. Increase to pump inlet size or one size larger 3. Reduce discharge head 4. Disassemble pump and clean impeller 5. Check motor operation
Noisy pump operation	1. Air trapped in housing 2. Rotor bearing worn 3. Debris in housing	1. Check pump prime, also turn pump on and off several times to bump air pocket out of pump 2. Replace rotor assembly 3. Disassemble pump and remove debris

Thermal Safety

⚠ WARNING: - Hot Water Hazard - Before draining the system, allow water to cool to at least 100°F, open the drain valve (take precautions against water damage) and leave the drain valve open until servicing is complete. Failure to follow these instructions could result in serious personal injury, death and/or property damage.

⚠ WARNING: - Extreme Temperature Hazard - If the pump, motor or piping are operating at extremely high or low temperature, guarding or insulation is required. Failure to follow these instructions could result in serious personal injury, death and/or property damage.